

**Contact Land, front fitment, for closure connectors, Turret solder connection  
LT-MEDIUM-LT**



**Test Probes & Interfacing Components**

Telephone: +44 (0)1787 478678

sales@codasystems.co.uk

technical@codasystems.co.uk

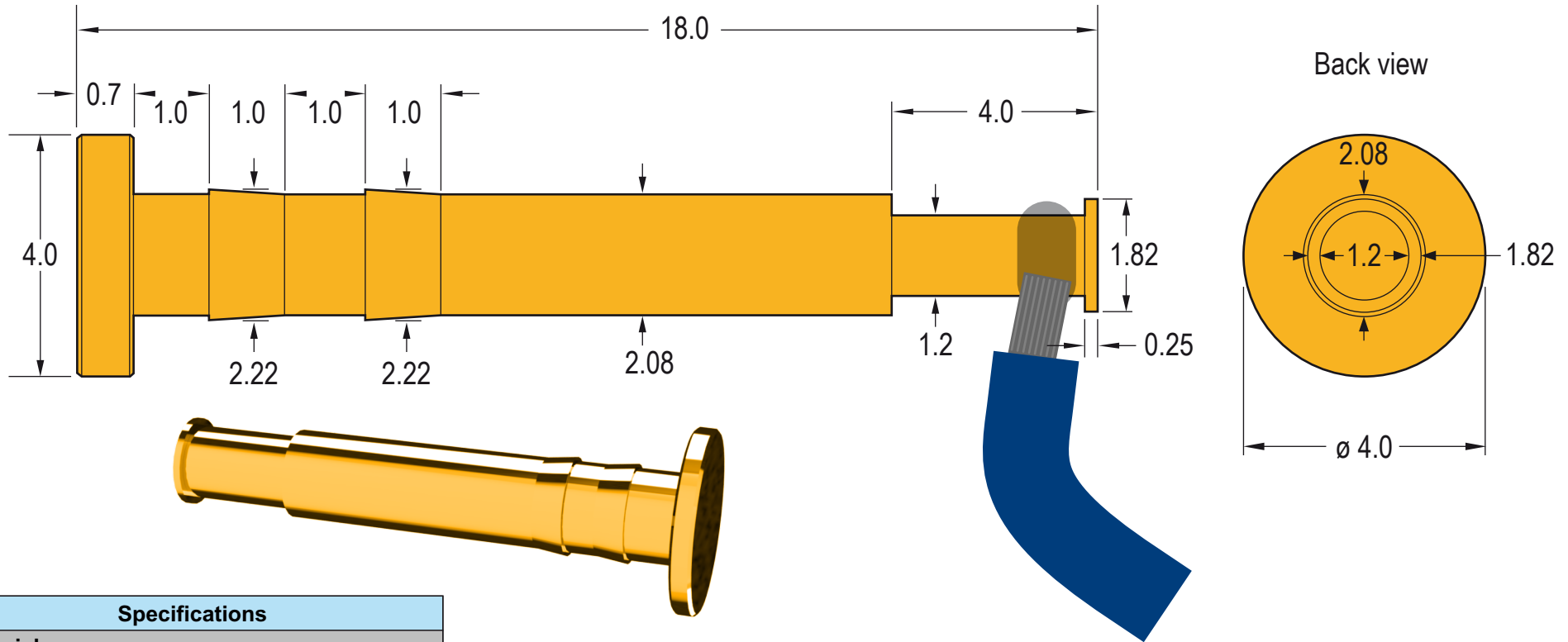

Specifications	
<b>Materials</b>	Brass CZ121
<b>Plating</b>	Gold plating over E. N. P.
<b>Installation</b>	<ul style="list-style-type: none"> <li>• Press fitment from the top</li> <li>• Mounting hole size; 2.15mm</li> <li>• Connection method; Solder cable around turret</li> <li>• Panel thickness; 5.0mm min.</li> </ul>

PART NUMBER <b>LT-MEDIUM-LT</b>		THE INFORMATION CONTAINED IN THIS DRAWING IS THE PROPERTY OF © CODA SYSTEMS LTD. NOT TO BE COPIED OR DISCLOSED TO A THIRD PARTY WITHOUT THE PRIOR, WRITTEN CONSENT OF CODA SYSTEMS LTD.	
SIZE <b>A4</b>	SCALE <b>NTS</b>	DRAWN IN ACCORDANCE WITH ISO STANDARDS	<b>UNLESS OTHERWISE SPECIFIED</b> 1. DIMENSIONS ARE IN MM 2. DIMENSIONAL LIMITS APPLY AFTER PLATING / COATING 3. REMOVE ALL BURRS AND BREAK EDGES .25 MAX 4. MACHINE FILLET RADIUS .25 MAX 5. MACHINED SURFACES FLAT WITHIN 0.08 mm/mm 6. NON-MACHINED SURFACES FLAT WITHIN 0.25 mm/mm 7. DIAMETERS ON COMMON CL TO BE CONCENTRIC WITHIN 0.13 8. PERPENDICULAR SURFACES TO BE SQUARE WITHIN .13 mm/mm 9. REFERENCE ( ) DIMENSIONS HAVE NO TOLERANCES
<b>RoHS Compliant?</b> <input checked="" type="checkbox"/>		DATE <b>14/04/23</b>	
		VERSION <b>D1</b>	