

Fitting

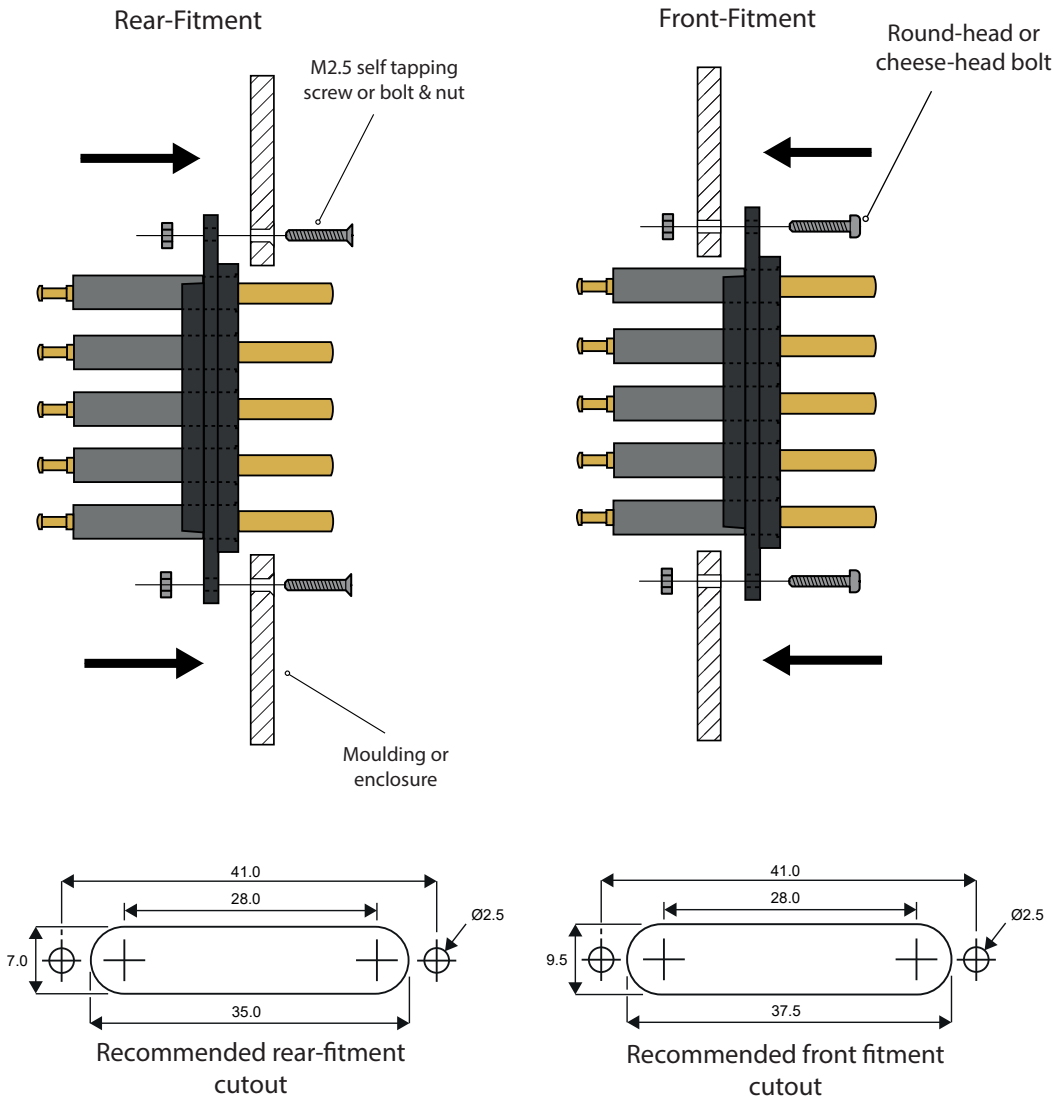

Soldering

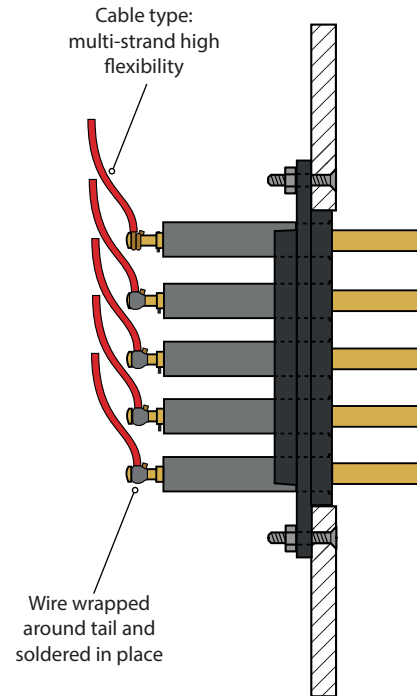

- Keep soldering time to a minimum on land side to avoid melting the plastic moulding that surrounds the land
 - Position wire perpendicular to pin
 - Wrap wire around inside of tail and twist tight. Solder quickly in one operation
- Gold plating will allow solder to take very quickly