

Fitting

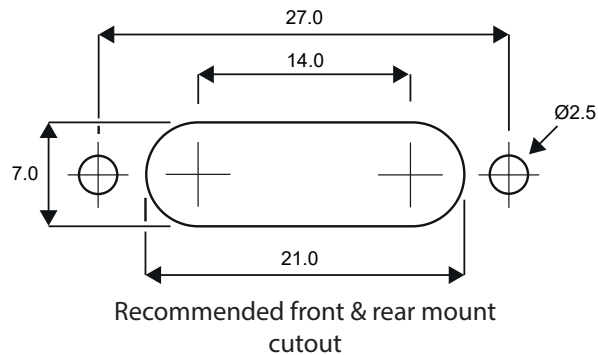

Soldering

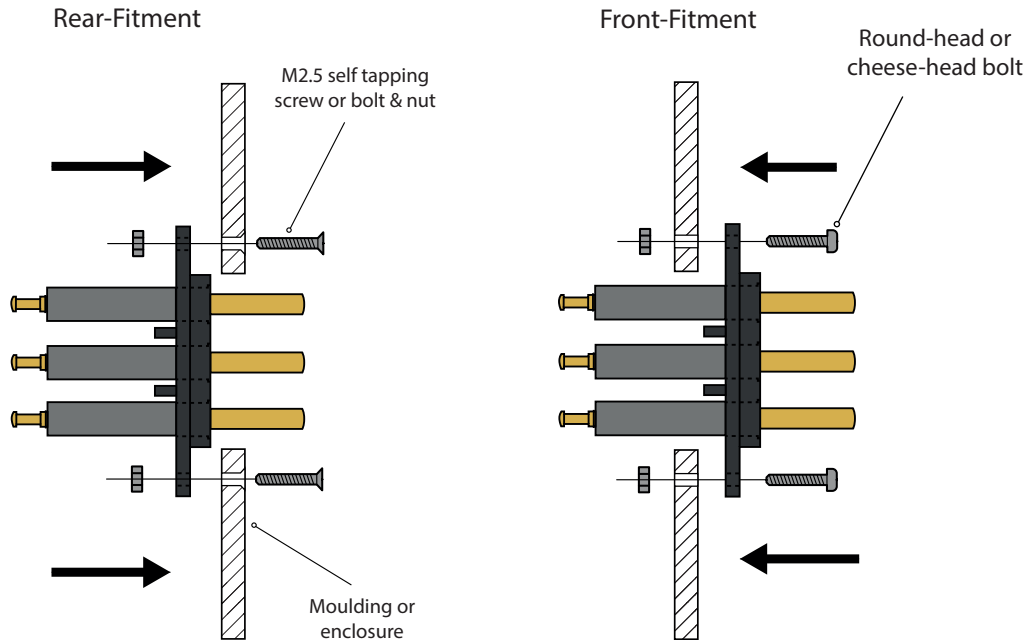
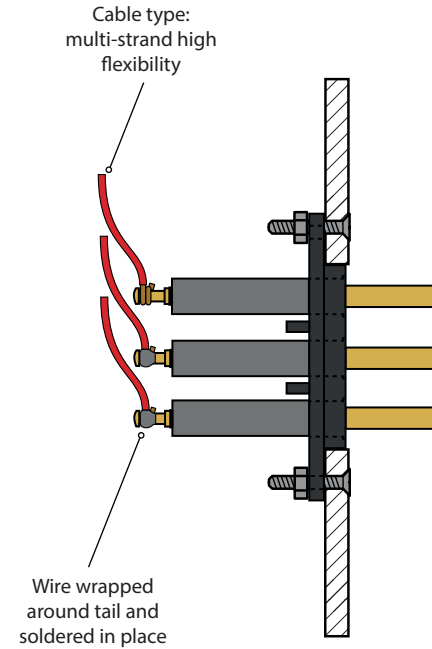

- Keep soldering time to a minimum on land side to avoid melting the plastic moulding that surrounds the land
- Position wire perpendicular to pin
- Wrap wire around inside of tail and twist tight. Solder quickly in one operation

Gold plating will allow solder to take very quickly