

# KWP100A Kelvin Pin Dimensions and Fitment Instructions

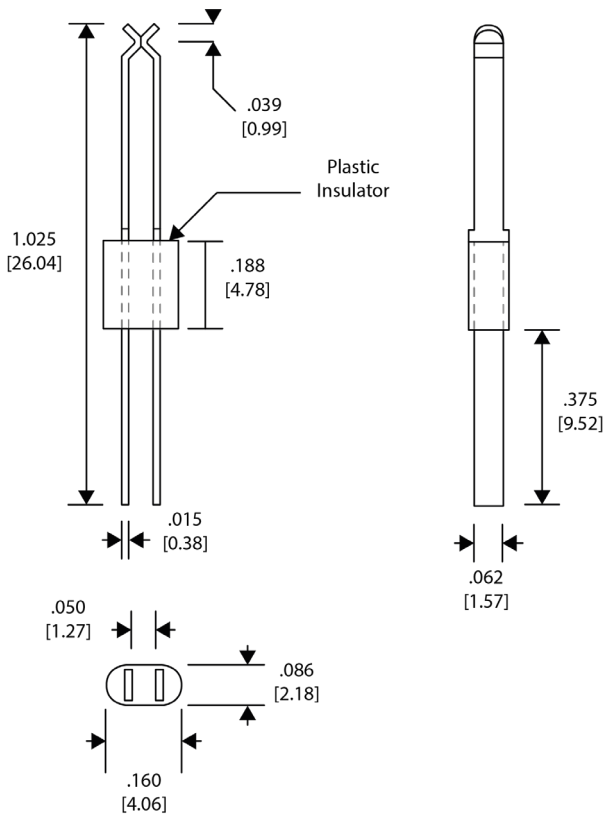

## Specification:

Component lead diameter range	0.5 to 0.8mm
Minimum test center spacing	2.54mm
Temperature rating max	100°C
Maximum current	15 amps
Number of insertion cycles max.	30k to 100k

## Materials:

Pin	Heat treated Beryllium copper alloy, gold plated over nickel
Insulator	Nylon 6/6

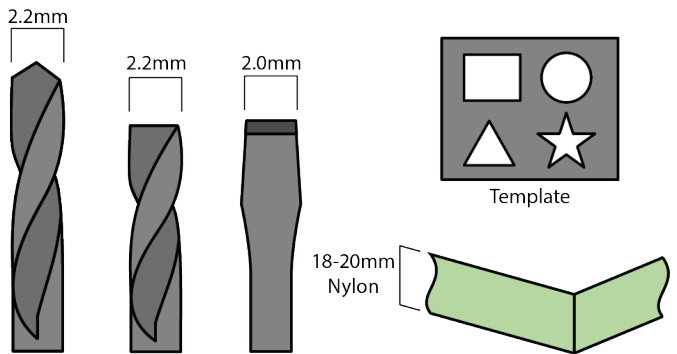

## Kelvin Pin Fitment Method for Testing Leaded Components

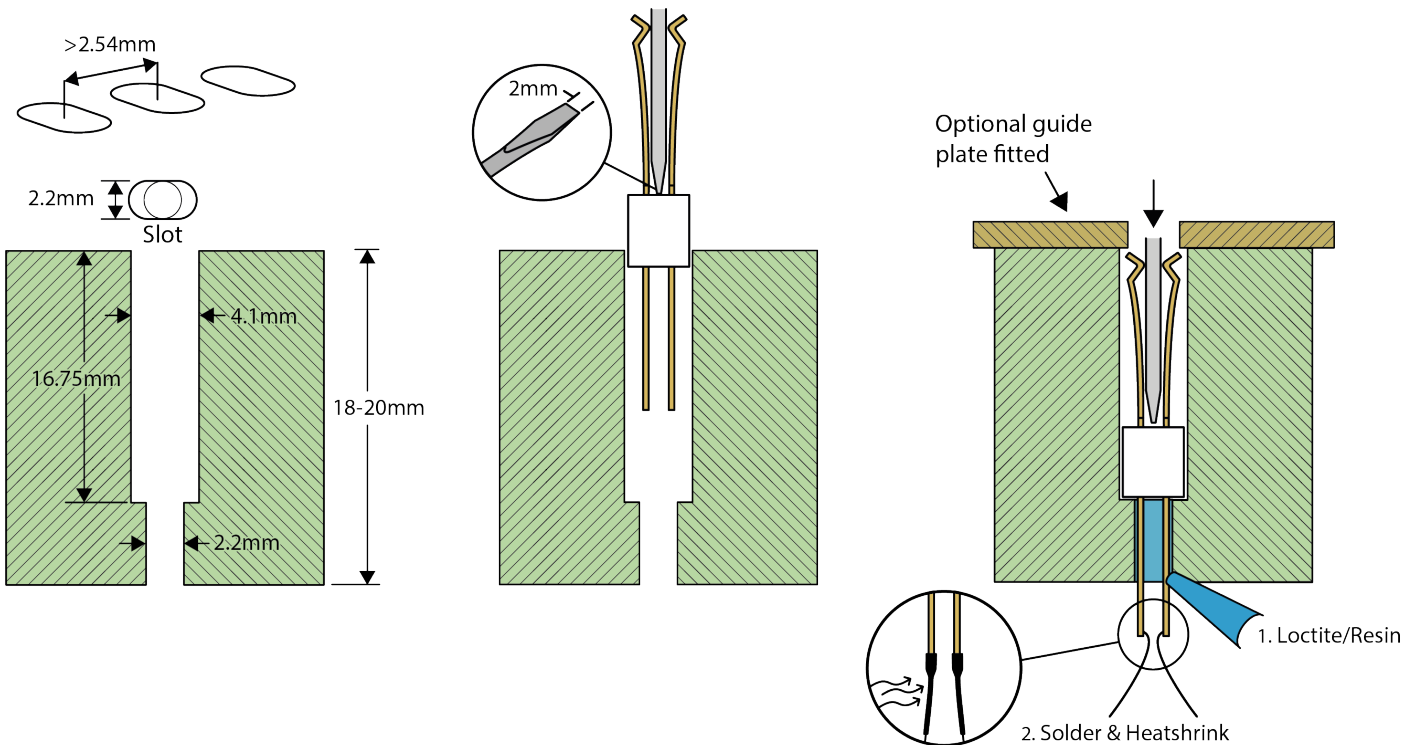

Coda Systems Ltd

Oak Road, Little Maplestead, HALSTEAD, CO9 2RT UK Tel: +44 (0)1787 478678 • Fax: +44 (0)1787 274194  
 sales@coda-systems.co.uk www.coda-systems.co.uk