

Contact land, press fitment IPP3



Test Probes & Interfacing Components

Telephone: +44 (0)1787 478678

sales@coda-systems.co.uk

technical@coda-systems.co.uk

Side view

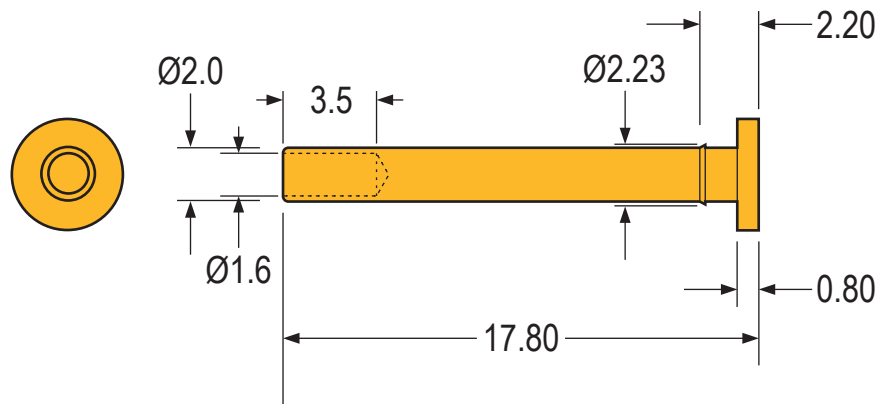

Back view

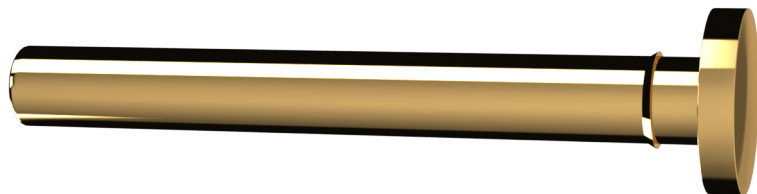

Specifications

Materials

Brass CZ121

Plating

0.25-0.50µm Au Hard Gold over 3-5µm Nickel

Installation

- Press fitment or over moulding
- Solder pot or solder in
- Drill hole size; 2.00-2.10mm
- Panel thickness; >2mm

PART NUMBER IPP3		THE INFORMATION CONTAINED IN THIS DRAWING IS THE PROPERTY OF © CODA SYSTEMS LTD. NOT TO BE COPIED OR DISCLOSED TO A THIRD PARTY WITHOUT THE PRIOR, WRITTEN CONSENT OF CODA SYSTEMS LTD.	
SIZE A4	SCALE NTS	DRAWN IN ACCORDANCE WITH ISO STANDARDS	UNLESS OTHERWISE SPECIFIED 1. DIMENSIONS ARE IN MM 2. DIMENSIONAL LIMITS APPLY AFTER PLATING / COATING 3. REMOVE ALL BURRS AND BREAK EDGES .25 MAX 4. MACHINE FILLET RADIUS .25 MAX 5. MACHINED SURFACES FLAT WITHING 0.08 mm/mm 6. NON-MACHINED SURFACES FLAT WITHIN 0.25 mm/mm 7. DIAMETERS ON COMMON CL TO BE CONCENTRIC WITHIN 0.13 8. PERPENDICULAR SURFACES TO BE SQUARE WITHIN .13 mm/mm 9. REFERENCE () DIMENSIONS HAVE NO TOLERANCES
RoHS Compliant? <input checked="" type="checkbox"/>			